

986K

Wheel Loader



Engine

Engine Model	Cat® C15 ACERT™	
Emissions	U.S. EPA Tier 4 Final/EU Stage IV, or China Nonroad Stage III and Brazil MAR-1 equivalent to Tier 3 and Stage IIIA	
Gross Power – ISO 14396	335 kW	449 hp

Buckets

Bucket Capacities	5-10.3 m ³	6.5-13.5 yd ³
Operating Specifications		
Rated Payload – Quarry Face	10 tonnes	11 tons
Rated Payload – Loose Material (Standard)	12.7 tonnes	14 tons
Rated Payload – Loose Material (High Lift)	11 tonnes	12.1 tons
Operating Weight	44 818 kg	98,806 lb

Lower your cost per ton with built-in durability.



Contents

- Structures.....4
- Power Train.....6
- Hydraulics8
- Operator Station.....10
- Technology Solutions12
- Safety13
- Serviceability14
- Customer Support.....14
- Sustainability15
- Bucket Ground Engaging Tools16
- System Match Efficiency.....18
- Specifications.....19
- Standard Equipment.....28
- Optional Equipment.....29
- Mandatory Attachments.....30
- Notes.....31



Cat® Large Wheel Loaders are designed with durability built in, ensuring maximum availability through multiple life cycles. With optimized performance and simplified serviceability, our machines allow you to move more material efficiently and safely at a lower cost per ton.

The new 986K builds upon this legacy of durability, performance, safety, operator comfort, serviceability and sustainability.

Structures

Best built for the toughest conditions.

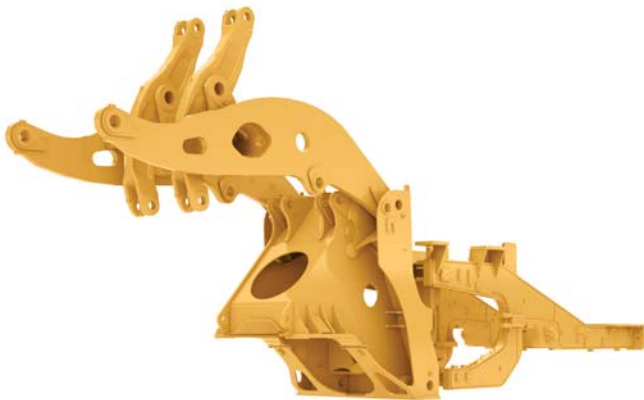

Lift Arms

Your key to maximum uptime and productivity is our field-proven lift arms.

- Excellent visibility to the bucket edges and work area through a Z-bar design.
- High load stresses are absorbed by the solid steel lift arms.
- Enhance strength in key pin areas through the use of one piece castings.



Robust Structures

Your bottom line is improved by highly durable structures that achieve multiple life cycles and withstand the toughest loading conditions.

- Full box-section rear frame resists torsional shock and twisting forces.
- Heavy-duty steering cylinder mounts efficiently transmit loads into the frame.
- Cast axle pivot mounting areas better disperse stress loads for increased structural integrity.



Front Linkage

To ensure long life and reliability, the linkage pin joints feature a greased pin design with optional auto lube system.

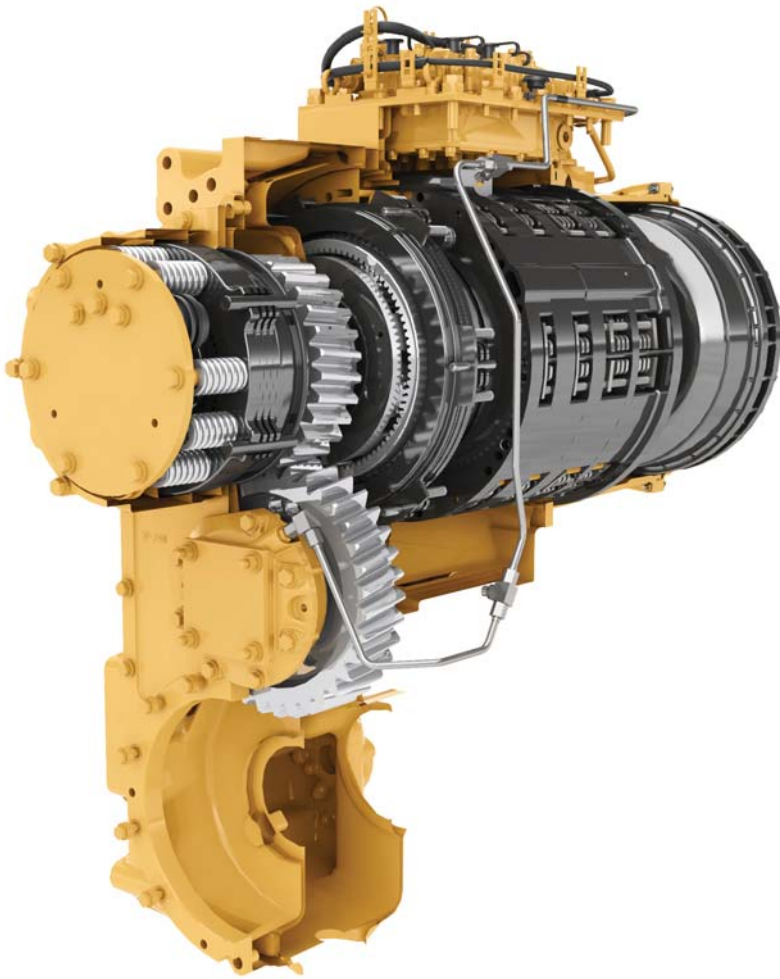

Cat® Planetary Powershift Transmission

Building your success begins with a best-in-class transmission designed specifically for mining applications.

- Consistent, smooth shifting and efficiency through integrated electronic controls.
- Heat treated gears and shafts extend component life and maximize reliability.
- Four forward and four reverse speeds to match your application.

Cat C15 ACERT Engine

Durability and efficiency at the heart of your 986K comes from the Cat® C15 ACERT engine. Optimum performance is built in to this 6 cylinder turbocharged engine.

- Meets Tier 4 Final/Stage IV, or China Nonroad Stage III and Brazil MAR-1 emission standards equivalent to Tier 3 and Stage IIIA.
- Mechanically Actuated Electronic Unit Injection (MEUI™) gives the C15 ACERT complete control over injection timing, duration and pressure.
- The Advanced Diesel Engine Management (ADEM™) A4 electronic control module manages fuel delivery to optimize performance and provide quick engine response.





Power Train

Move material more efficiently with improved power and control.

Transmission Neutralizer Pedal

- Extends service brake life by neutralizing transmission as service brakes are applied.
 - Allows full power to implement system while the machine is stationary during truck loading.
- 1 **Set Point for Neutralization** – Start of service brake pressure modulation
 - 2 **Full Pedal Travel** – Maximum brake pressure



Hydraulics

Productivity enabling you to move more and make more.



Load Sense Hydraulics

Increase efficiency through our Load Sense Hydraulic System. Load sense hydraulics maximize performance by directing hydraulic fluid flow through implement and steering system only when needed.

- Lowered fuel consumption.
- Consistent performance and efficiency with lower system heat.

Electro Hydraulic Controls

Operators increase productivity with our responsive implements feature.

- Operate comfortably through electronically controlled hydraulic cylinder stops.
- Handle easy-to-use soft detent controls.
- Conveniently set automatic implement kickouts from inside the cab.



Steering System

Confident loader operation starts with precise machine control enabled by the 986K's load sensing hydraulic steering system.

- Increase efficiency with our variable displacement piston pumps.
- Achieve precise positioning for easy loading in tight areas with 35 degrees of steering articulation.
- Enhance operator comfort with integrated steering and transmission control functions.

Filtration System

Benefit from extended performance and reliability of your hydraulic system with our advanced filtration system.

- Hydraulic oil cooler return filter.
- Pilot filter.
- Return and case drain screens inside hydraulic tank.
- Axle oil cooler screens if equipped.





Your operators can work more efficiently and stay comfortable with our customer-inspired cab features.

Entry and Exit

Enter and exit the cab easily and safely with these newly designed, ergonomic features.

- Fold up STIC™ steer/armrest.
- Reduced access stairway angles.
- Standard stairway lighting.

Cat Comfort Series III Seat

Enhance comfort and helps reduce operator fatigue with Cat Comfort Series III seat.

- Mid back design and extra thick, contoured cushions.
- Air suspension system.
- Easy-to-reach seat levers and controls for six way adjustments.
- Seat-mounted implement pod and STIC steer that moves with the seat.
- 76 mm (3 in) wide retractable seat belt.
- Optional 4-point seat belt.

Control Panel

Ergonomic placement of switches and information display keep your operators comfortable all day every day.

- Large backlit membrane switches feature LED activation indicators.
- Switches feature ISO symbols for quick function identification.
- Two position rocker switch activates the electro hydraulic park brake.





Operator Station

Best-in-Class operator comfort and ergonomics.

Environment

Your operator's productivity is enhanced with our clean, comfortable cab environment.

- Experience reduced vibrations from isolated cab mounts and seat air suspension.
- Maintain desired cab temperature with automatic temperature controls.
- Pressurized cab with filtered air.
- Reduced operator sound levels.
- Convenient floor storage tray/lunch box.



Technology Solutions

Greater productivity through
Integrated Electronic Systems.

Integrated electronics provide flexible levels of information to both the site and the operator. This integration creates a smart machine and more informed operator, maximizing the productivity of both.

Information Display

We have worked hard to help our customers and operators perform at their best through our newly upgraded touch screen information display.

- Intuitive operation and easy navigation with our enhanced user interface.
- Decrease service time by keeping operators informed about machine systems.

Cat Production Measurement

Brings payload weighing to the cab, enabling operators to weight loads on-the-go during loading operations. Loads are weighed as the bucket is raised during the lift cycle – eliminating the need to interrupt the load cycle, improving loading efficiency.

- Operators can view load weights on the information display.
- Instant feedback gives operators the confidence to work more effectively.
- Operators can track recorded weights and cycles using the display.

Tire Pressure Monitoring System (TPMS)

Tire pressure monitoring is a fully integrated feature which allows operators to monitor inflation of tires. Available through the Information Display, the operator can quickly see the current pressure settings and temperature of each tire.

Cat Product Link™ Elite

Take the guesswork out of asset management with Product Link remote monitoring.

- Advanced Productivity App (Available as Subscription) helps to optimize worksite operations with detailed payload, cycle, fuel report and remote truck/material list management.
- Remote access to information through the easy-to-use VisionLink® interface.
- Maximize uptime by staying informed on machine systems and diagnostic codes.
- Track machine with utilization, fuel usage, and payload summaries.
- Stay up to date on machine location, service meter hours, and reporting status.

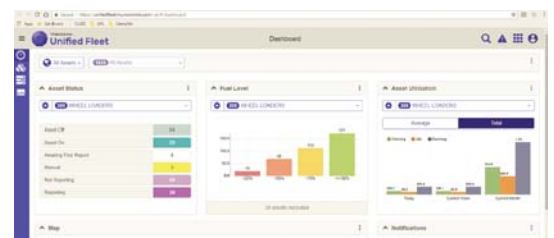
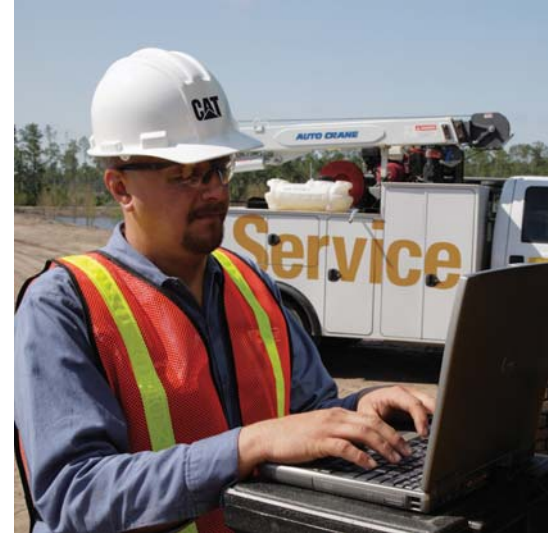

Safety

Making your safety our priority.

We are constantly improving our products in an effort to provide a safe work environment for the operator and those who work on your job site.

Machine Access

- Machines equipped with left and right hand stairs with 45 degree angle enhance safety for operators getting on and off the 986K.
- Continuous walkway with non-skid surfaces are designed into the service areas.
- Maintain three points of contact at all times through ground level or platform accessible service areas.



Visibility

- External guardrail mounted rearview mirrors ensure enhanced visibility for safe operation.
- Cat Vision and optional Cat Detect with radar increase operator awareness around the machine.
- Halogen, HID, or LED lights provide excellent workspace visibility.
- Cab mounted LED warning beacons.

Operator Environment

- Reduced vibrations to the operator with isolated cab mounts and seat mounted implement and steering controls.
- Low interior sound levels.
- Pressurized cab with filtered air.
- Standard 76 mm (3 in) seat belts on the operator seat.

Serviceability

Enabling high uptime by reducing your service time.



We can help you succeed by ensuring your 986K has design features to reduce your downtime.

- Longer service intervals on fluids and filters.
- Safe and convenient service with ground level or platform access and grouped service points.
- Centralized, ground level grease points for injecting grease into linkage pin joints.
- Centralized remote pressure taps for power train components.
- Ground electrical service center with Jump Start Receptacle, Emergency engine shutdown switch, Battery disconnect switch and Circuit breakers.

Customer Support

Your Cat dealers know how to keep your mining machines productive.

Legendary Cat Dealer Support

A valued partner, your Cat dealer is available whenever you need them.

- Preventive maintenance programs and guaranteed maintenance contracts.
- Best-in-class parts availability.
- Improve your efficiency with operator training.
- Genuine Cat Remanufactured parts.



Sustainability

Reducing impact to the environment.



Reducing Impact to the Environment

Sustainability is designed and built into our 986K's features.

- Engine Idle Shutdown can help you save fuel by avoiding unnecessary idling.
- Reduce waste with our maintenance free or extended maintenance batteries.
- To assist with maximizing machine life, Caterpillar provides a number of sustainable options such as our Reman and Certified Rebuild programs. In these programs, reused or remanufactured components can deliver cost savings of 40 to 70 percent, which lowers operating cost while reducing impact to the environment.
- Caterpillar offers retrofit packages to bring new features to older machines, maximizing your resource. And, when you go through the Cat Certified Rebuild program, these retrofit kits are part of the rebuild process.

Bucket Ground Engaging Tools

Protect your investment.

Performance Series Buckets

Performance Series Buckets feature an optimized profile maximizing material retention and minimizing dig time, translating into significant productivity and fuel efficiency improvements. All 986K buckets are manufactured with the Performance Series design.



1 – Rock Buckets

Designed for use in bank or face loading of limestone and other unprocessed rock. Application also includes truck and hopper loading for a wide range of quarry materials. GET includes spade nose cutting edge with adapters, half arrow segments, bottom wear plates, and side bar protectors.

2 – Heavy Duty Rock Buckets

Designed for use in applications like face loading tightly compacted pit materials or handling materials of moderate abrasion and high impacts. GET are similar to the rock bucket with the addition of floor liner, half radius liners and bolt-on bottom edge wear plates. 20-series mechanically attached wear plates (MAWPS) are provided for additional wear protection and improved serviceability. Base edge end protection, ski plates, additional side wear plates, wings and an extra set of side bar protectors are also included.

3 – General Purpose Buckets

Designed for use primarily in stockpiling, re-handling and aggregate applications. GET includes a straight base edge with a bolt-on cutting edge system. Curved side bars are provided to aid in material retention.

4 – Coal Buckets

Designed with a larger capacity for use in applications with light density and non-abrasive materials. GET includes a straight base edge with a bolt-on cutting edge system.

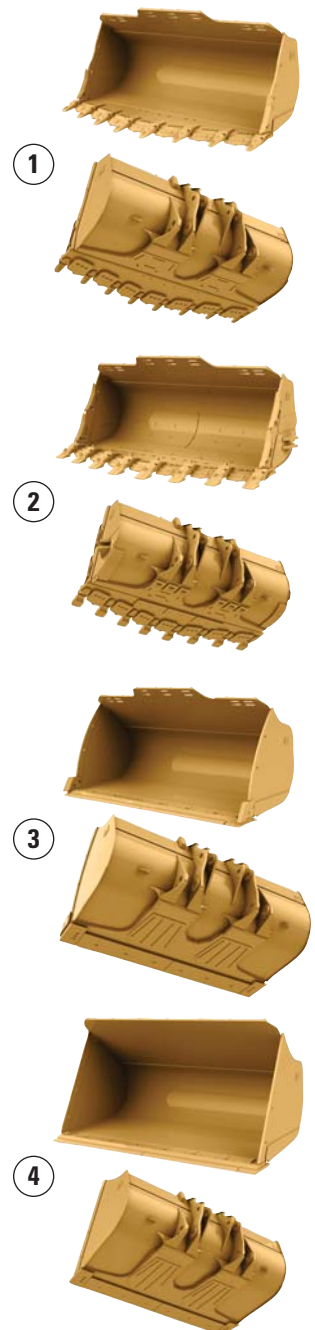

Cat Advansys™ Ground Engaging Tools

Protect expensive components. Reduce your operating costs. Get the most out of your machine's performance. Choose from a variety of performance-built Advansys GET like these to meet your application requirements.

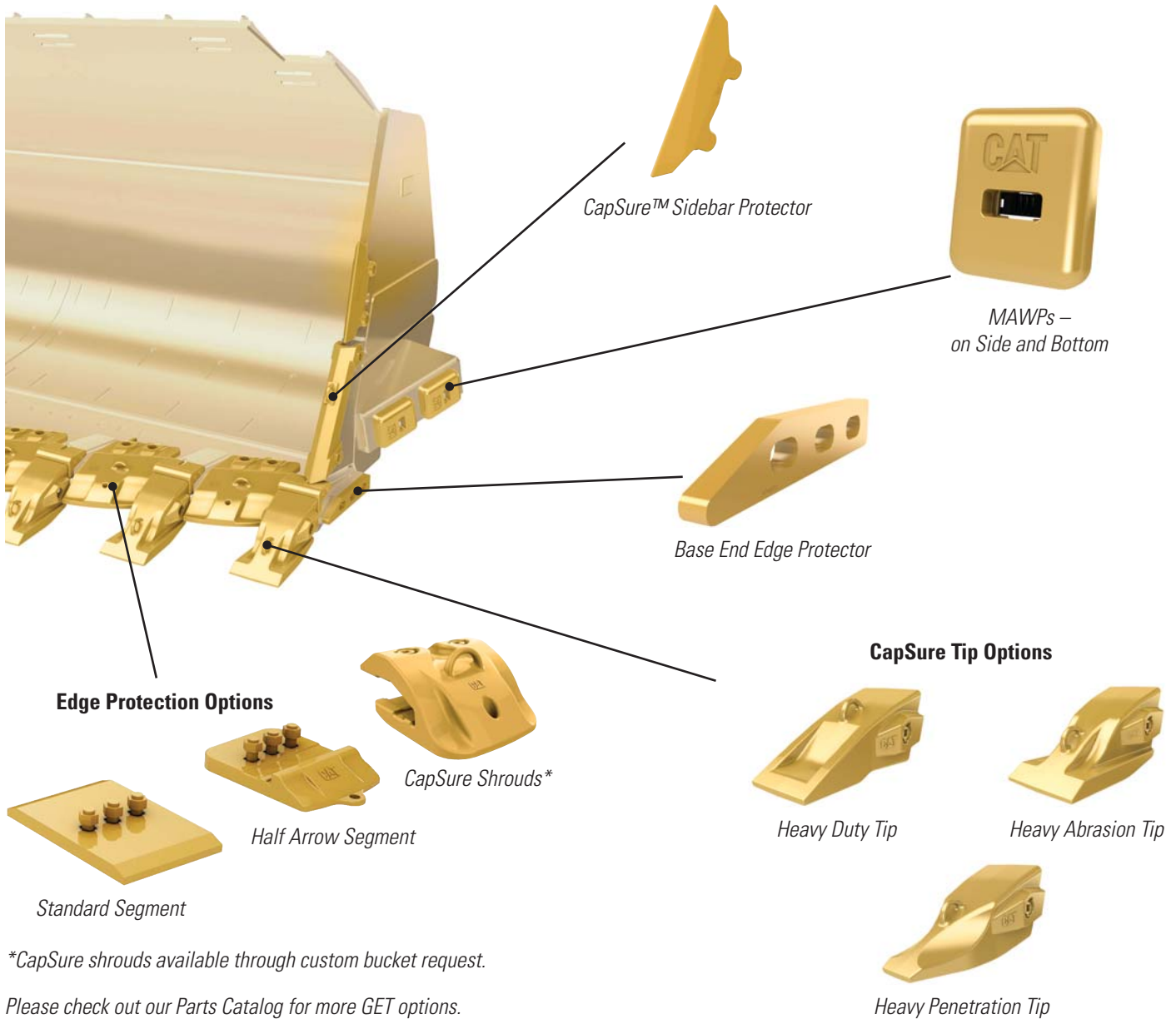

*CapSure shrouds available through custom bucket request.

Please check out our Parts Catalog for more GET options.

CapSure™ Retention Technology

Simplify GET component replacement with hammerless CapSure retention for fast, easy and safe installation. CapSure tips, shrouds and sidebar protectors are easily locked and unlocked with a 180 degree turn of a 3/4 inch (19 mm) ratchet.



System Match Efficiency

Efficient loading/hauling system starts with a perfect match.

	735C	740C/745C	770G	772G	773E/773G
Standard Lift	3	4	4		
High Lift				5	6

Efficient Combination

For full truck payloads with minimum loading time, an efficient loading/hauling system starts with a perfect match. Cat wheel loaders are matched with Cat articulated and off-highway trucks to maximize volume of material moved at the lowest operating cost per ton.

The 986K equipped with the standard linkage is a perfect four pass match for the 770G (38.6 tonnes/42.6 tons). The 986K equipped with a high lift linkage is capable of loading a 772G (47.7 tonnes/52 tons) in 5 passes and a 773E or 773G (56 tonnes/61.7 tons) in 6 passes.

986K Wheel Loader Specifications

Engine

Engine Model	Cat C15 ACERT	
Emissions	Tier 4 Final/Stage IV, or China Nonroad Stage III and Brazil MAR-1 equivalent to Tier 3 and Stage IIIA	
Peak Power Speed	1,600 rpm	
SAE J1995	340 kW	456 hp
SAE J1995 (DIN)	462 hp	
ISO 14396	335 kW	449 hp
ISO 14396 (DIN)	455 hp	
Rated Speed	2,000 rpm	
EEC 80/1269	278 kW	373 hp
EEC 80/1269 (DIN)	378 hp	
ISO 9249	278 kW	373 hp
ISO 9249 (DIN)	378 hp	
SAE J1349	278 kW	373 hp
SAE J1349 (DIN)	378 hp	
Bore	137 mm	5.4 in
Stroke	171.5 mm	6.75 in
Displacement	15.2 L	927 in ³
Peak Torque @ 1,200 rpm – SAE J1995	2411 N·m	1,778 lb-ft
Torque Rise	16%	

Operating Specifications

Operating Weight – Standard	44 355 kg	97,785 lb
Operating Weight – High Lift	47 175 kg	104,005 lb
Rated Payload – Standard (Quarry Face)	10 tonnes	11 tons
Rated Payload – Standard (Loose Material)	12.7 tonnes	14 tons
Rated Payload – High Lift (Quarry Face)	10 tonnes	11 tons
Rated Payload – High Lift (Loose Material)	11 tonnes	12.1 tons
Bucket Capacity Range	5-10.3 m ³	6.5-13.5 yd ³
Cat Truck Match – Standard	770/735/740/745	
Cat Truck Match – High Lift	772/773	

Transmission

Transmission Type	Cat Planetary Power Shift	
Forward 1	7.3 km/h	5 mph
Forward 2	12.2 km/h	8 mph
Direct Drive – Forward 2	12.7 km/h	8 mph
Direct Drive – Forward 3	22 km/h	14 mph
Direct Drive – Forward 4	39 km/h	24 mph
Reverse 1	7.6 km/h	5 mph
Reverse 2	13.6 km/h	8 mph
Direct Drive – Reverse 2	14.1 km/h	9 mph
Direct Drive – Reverse 3	25 km/h	16 mph
Direct Drive – Reverse 4	40.8 km/h	25.4 mph

Hydraulic System – Lift/Tilt

Lift/Tilt System – Circuit	Load Sense	
Lift/Tilt System Pumps	2 × 110 cc variable displacement	
Maximum Flow at 2,165 rpm	470 L/min	123 gal/min
Relief Valve Setting – Lift/Tilt	27 900 kPa	4,050 psi
Lift Cylinder – Bore	190 mm	7.5 in
Lift Cylinder – Stroke	1138 mm	45 in
Tilt Cylinder – Bore	170 mm	6.7 in
Tilt Cylinder – Stroke	722 mm	28.4 in

986K Wheel Loader Specifications

Hydraulic Cycle Time

Rackback	4.5 Seconds
Raise	9 Seconds
Dump	3.5 Seconds
Lower	5.2 Seconds
Lower Float Down	4.3 Seconds
Total Hydraulic Cycle Time	21.3 Seconds

Service Refill Capacities

Fuel Tank	535 L	141 gal
Fuel Tank (Short Lift)	481 L	127 gal
Cooling Systems	100 L	26 gal
Crankcase	34 L	9 gal
Diesel Exhaust Fluid Tank (Tier 4 Final/Stage IV only)	23 L	6 gal
Transmission	75 L	20 gal
Axle Oil		
Differentials and Final Drives – Front	186 L	49 gal
Differentials and Final Drives – Rear	170 L	45 gal
Hydraulic System Factory Fill	330 L	87 gal
Hydraulic System (tank only)	130 L	34 gal

Air Conditioning System

The air conditioning system on this machine contains the fluorinated greenhouse gas refrigerant R134a (Global Warming Potential = 1430). The system contains 1.8 kg of refrigerant which has a CO₂ equivalent of 2.574 metric tonnes.

Axles

Front	Fixed
Rear	Trunnion
Oscillation Angle	±12.5°
Oscillation Angle (chain arrangement)	±8.5°

Brakes

Brakes	ISO 3450:2011
--------	---------------

Hydraulic System – Steering

ISO 5010:2007		
Steering System – Circuit	Load Sense	
Steering System – Pump	Piston, variable displacement	
Maximum Flow @ 1,400 rpm	200 L/min	52 gal/min
Steering Cutoff Pressure	27 600 kPa	4,000 psi
Total Steering Angle	70°	

Operator Cab

ROPS/FOPS	ROPS/FOPS meet ISO 3471:2008 (ROPS) and ISO 3449:2005 Level II (FOPS)
-----------	---

Sound Performance

	Standard	Suppression
Operator Sound Level (ISO 6396)	72 dB(A)	72 dB(A)
Machine Sound Level (ISO 6395)	112 dB(A)	110 dB(A)

- The operator sound pressure level was measured according to the test procedures and conditions specified in ISO 6396:2008. The measurement was conducted at 70 percent of the maximum engine cooling fan speed.
- Hearing protection may be needed when the machine is operated with a cab that is not properly maintained or when the doors or windows are open for extended periods or in a noisy environment.
- The machine sound power level was measured according to the test procedures and conditions specified in ISO 6395:2008. The measurement was conducted at 70 percent of the maximum engine cooling fan speed.

986K Wheel Loader Specifications

Dimensions

All dimensions are approximate.

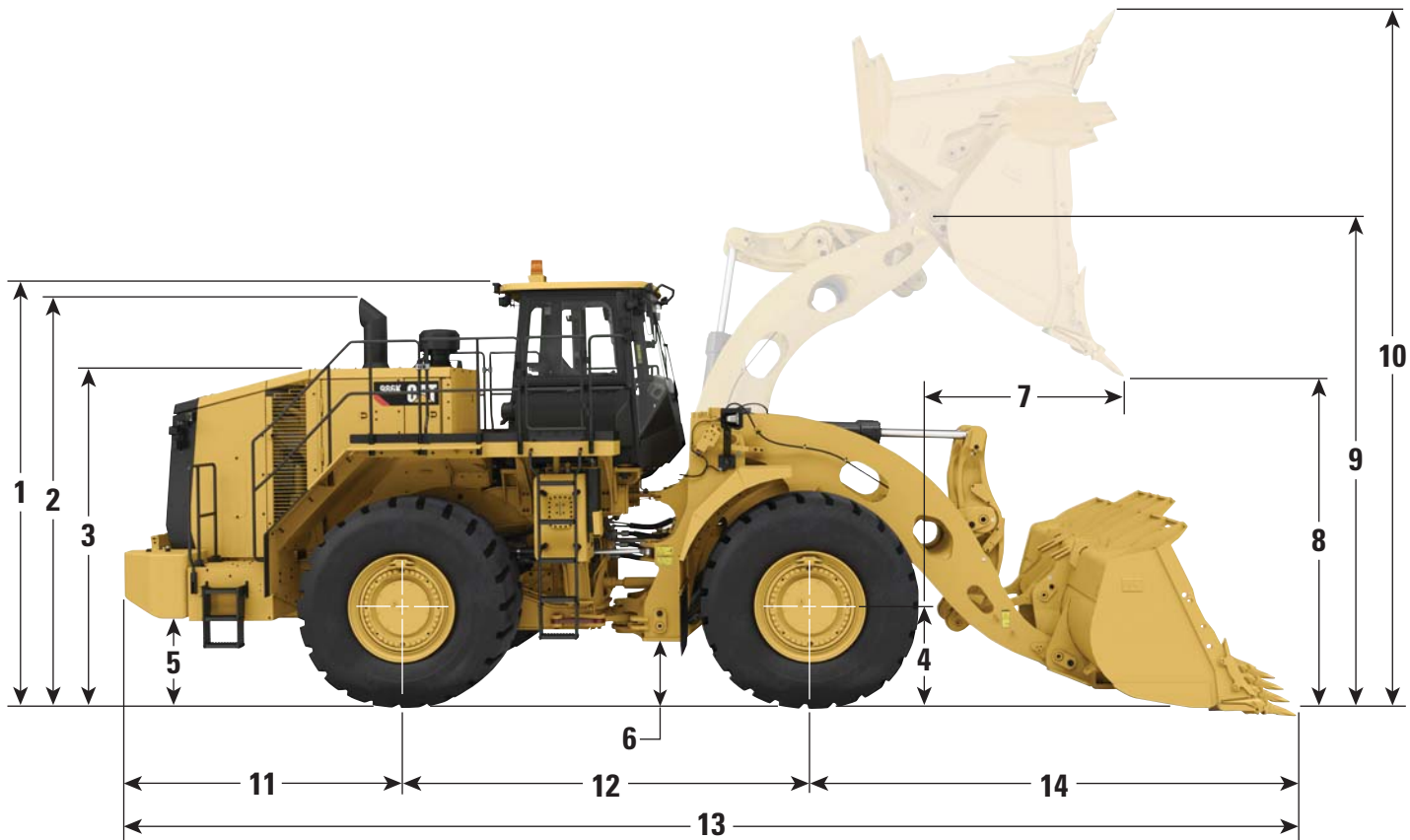

	Standard Lift Linkage		High Lift Linkage	
1 Ground to Top of ROPS	4100 mm	13.5 ft	4100 mm	13.5 ft
2 Ground to Top of Exhaust Stacks	4060 mm	13.3 ft	4060 mm	13.3 ft
3 Ground to Top of Hood	3270 mm	10.7 ft	3270 mm	10.7 ft
4 Ground to Center of Front Axle	978 mm	3.2 ft	978 mm	3.2 ft
5 Ground to Fuel Tank Clearance	691 mm	2.3 ft	691 mm	2.3 ft
6 Ground to Lower Hitch Clearance	459 mm	1.5 ft	459 mm	1.5 ft
7 Reach at Maximum Lift	2175 mm	7.1 ft	2248 mm	7.4 ft
8 Clearance at Maximum Lift	3079 mm	10.1 ft	3538 mm	11.6 ft
9 B-Pin Height at Maximum Lift	4912 mm	16.1 ft	5371 mm	17.6 ft
10 Maximum Overall Height, Bucket Raised	6817 mm	22.4 ft	7276 mm	23.9 ft
11 Rear Axle Center Line to Bumper	3132 mm	10.3 ft	3132 mm	10.3 ft
12 Wheel Base	3810 mm	12.5 ft	3810 mm	12.5 ft
13 Maximum Overall Length	11 143 mm	36.6 ft	11 591 mm	38.0 ft
14 Front Axle Centerline to Bucket Tip	4201 mm	13.8 ft	4649 mm	15.3 ft

Note: Specs are calculated with a 6.1 m³ (8.0 yd³) rock bucket.

986K Wheel Loader Specifications

Bucket Capacity/Material Density Selection Guide

Rock Buckets – Standard Lift/High Lift – 10 tonnes (11 tons) Rated Payload (Quarry Face)

Material Density				Bucket Volume	
kg/m ³	lb/yd ³	tonnes/m ³	tons/yd ³	m ³	yd ³
1632-1795	2,750-3,025	1.63-1.80	1.38-1.51	6.1	8.0
1740-1914	2,933-3,227	1.74-1.91	1.46-1.61	5.7	7.5
1865-2051	3,143-3,457	1.86-2.05	1.57-1.73	5.4	7.0

General Purpose Buckets – Standard Lift – 12.7 tonnes (14 tons) Rated Payload (Loose Material)*

Material Density				Bucket Volume	
kg/m ³	lb/yd ³	tonnes/m ³	tons/yd ³	m ³	yd ³
1512-1663	2,545-2,800	1.51-1.66	1.27-1.40	8.4	11
1671-1838	2,800-3,080	1.67-1.84	1.40-1.54	7.6	10
1984-2183	3,111-3,422	1.98-2.18	1.56-1.71	6.9	9

General Purpose Buckets – High Lift – 11 tonnes (12.1 tons) Rated Payload (Loose Material)

Material Density				Bucket Volume	
kg/m ³	lb/yd ³	tonnes/m ³	tons/yd ³	m ³	yd ³
1310-1440	2,200-2,420	1.31-1.44	1.10-1.21	8.4	11
1447-1592	2,420-2,662	1.45-1.59	1.21-1.33	7.6	10
1719-1891	2,689-2,958	1.72-1.89	1.34-1.48	6.9	9

*Requires aggregate handler attachment.

Note: Rated Payload is the material weight in the bucket that the loader is designed to carry, excluding the weight of the bucket, GET, and wear material. Rated Payloads are published at 100%, even though Caterpillar does allow 110%. These values are given in terms of mass. There is no consideration to loose density weights of various materials since they are so diverse.

Operating Specifications – Standard Lift

Bucket Type		Rock			HD Rock
Ground Engaging Tools		Teeth & Segments			Teeth & Segments
Cutting Edge Type		Spade			Spade
Bucket Part No.		527-4050	527-4060	525-6140	527-4070
Struck Capacity	m ³	4.4	4.8	5.1	4.4
	yd ³	5.8	6.2	6.7	5.8
Heaped Capacity (rated)	m ³	5.4	5.7	6.1	5.4
	yd ³	7.0	7.5	8.0	7.0
Width	mm	3812	3812	3812	3840
	ft	12.5	12.5	12.5	12.6
Dump Clearance at Full Lift and 45° Discharge (edge)	mm	3363	3317	3278	3346
	ft	11.0	10.9	10.8	11.0
Dump Clearance at Full Lift and 45° Discharge (with teeth)	mm	3164	3118	3079	3116
	ft	10.4	10.2	10.1	10.2
Reach at Lift and 45° Discharge (edge)	mm	1922	1968	2007	1969
	ft	6.3	6.5	6.6	6.5
Reach at Lift and 45° Discharge (with teeth)	mm	2090	2136	2175	2143
	ft	6.9	7.0	7.1	7.0
Reach with Lift Arms Horizontal and Bucket Level	mm	3820	3885	3940	3891
	ft	12.5	12.7	12.9	12.8
Digging Depth	mm	155	155	155	134
	in	6.1	6.1	6.1	5.3
Overall Length	mm	11 023	11 088	11 143	11 077
	ft	36.2	36.4	36.6	36.3
Overall Height with Bucket at Full Raise	mm	6716	6771	6817	6716
	ft	22.0	22.2	22.4	22.0
Loader Clearance Turning Radius (SAE carry with teeth)	mm	8714	8731	8745	8752
	ft	28.6	28.6	28.7	28.7
Full Dump Angle	deg	-50	-50	-50	-50
Static Tipping Load Straight (no tire squash)	kg	28 760	28 557	28 400	27 744
	lb	63,404	62,958	62,611	61,165
Static Tipping Load Straight (with tire squash)	kg	27 211	26 999	26 834	26 204
	lb	59,990	59,523	59,159	57,770
Static Tipping Load – Full Turn (articulated 35°) (no tire squash)	kg	25 403	25 207	25 056	24 387
	lb	56,004	55,572	55,238	53,765
Static Tipping Load – Full Turn (articulated 35°) (with tire squash)	kg	23 110	22 902	22 742	22 106
	lb	50,949	50,490	50,137	48,735
Breakout Force	kN	336	323	313	325
	lbf	75,576	72,620	70,292	72,961
Operating Weight	kg	44 605	44 732	44 818	45 505
	lb	98,336	98,616	98,806	100,320
Weight Distribution at SAE Carry (unloaded) – Front	kg	23 207	23 440	23 602	24 767
	lb	51,162	51,676	52,034	54,601
Weight Distribution at SAE Carry (unloaded) – Rear	kg	21 398	21 292	21 215	20 738
	lb	47,174	46,940	46,772	45,719
Weight Distribution at SAE Carry (loaded) – Front	kg	39 865	40 131	40 324	41 412
	lb	87,887	88,475	88,898	91,297
Weight Distribution at SAE Carry (loaded) – Rear	kg	14 740	14 600	14 494	14 093
	lb	32,496	32,188	31,954	31,070

986K Wheel Loader Specifications

Operating Specifications – Standard Lift

Bucket Type		General Purpose				Serrated	Coal
Ground Engaging Tools		BOCE					BOCE
Cutting Edge Type		Straight				Spade	Straight
Bucket Part No.		512-1180	513-7400	513-7420	477-1900	519-1465	513-7450
Struck Capacity	m ³	5.2	5.9	6.6	7.3	5.1	9.0
	yd ³	6.8	7.7	8.6	9.6	6.7	11.8
Heaped Capacity (rated)	m ³	6.1	6.9	7.7	8.4	6.1	10.3
	yd ³	8.0	9.0	10.0	11.0	8.0	13.5
Width	mm	3729	3729	3729	3729	3812	3729
	ft	12.2	12.2	12.2	12.2	12.5	12.2
Dump Clearance at Full Lift and 45° Discharge (edge)	mm	3488	3403	3311	3222	3328	3117
	ft	11.4	11.2	10.9	10.6	10.9	10.2
Dump Clearance at Full Lift and 45° Discharge (with teeth)	mm	—	—	—	—	3131	—
	ft	—	—	—	—	10.3	—
Reach at Lift and 45° Discharge (edge)	mm	1815	1900	1992	2081	2013	2161
	ft	6.0	6.2	6.5	6.8	6.6	7.1
Reach at Lift and 45° Discharge (with teeth)	mm	—	—	—	—	2210	—
	ft	—	—	—	—	7.3	—
Reach with Lift Arms Horizontal and Bucket Level	mm	3396	3516	3646	3772	3928	3903
	ft	11.1	11.5	12.0	12.4	12.9	12.8
Digging Depth	mm	143	143	143	143	115	160
	in	5.6	5.6	5.6	5.6	4.5	6.3
Overall Length	mm	10 589	10 709	10 839	10 965	11 099	11 110
	ft	34.7	35.1	35.6	36.0	36.4	36.4
Overall Height with Bucket at Full Raise	mm	6860	6964	7078	7000	6779	7219
	ft	22.5	22.8	23.2	23.0	22.2	23.7
Loader Clearance Turning Radius (SAE carry with teeth)	mm	8663	8693	8727	8761	8769	8832
	ft	28.4	28.5	28.6	28.7	28.8	29.0
Full Dump Angle	deg	-50	-50	-50	-50	-50	-50
Static Tipping Load Straight (no tire squash)	kg	29 324	28 943	28 546	28 212	28 869	27 788
	lb	64,649	63,808	62,933	62,196	63,646	61,261
Static Tipping Load Straight (with tire squash)	kg	27 729	27 331	26 916	26 566	27 305	26 080
	lb	61,132	60,254	59,340	58,568	60,197	57,496
Static Tipping Load – Full Turn (articulated 35°) (no tire squash)	kg	25 962	25 594	25 211	24 890	25 535	24 465
	lb	57,237	56,426	55,581	54,874	56,295	53,936
Static Tipping Load – Full Turn (articulated 35°) (with tire squash)	kg	23 611	23 223	22 817	22 477	23 223	21 973
	lb	52,053	51,198	50,303	49,553	51,198	48,442
Breakout Force	kN	374	346	319	297	323	275
	lbf	84,131	77,794	71,825	66,831	72,664	61,799
Operating Weight	kg	44 255	44 486	44 730	44 905	44 391	45 332
	lb	97,564	98,074	98,612	98,997	97,864	99,939
Weight Distribution at SAE Carry (unloaded) – Front	kg	22 496	22 913	23 357	23 692	22 811	24 503
	lb	49,594	50,514	51,493	52,233	50,290	54,019
Weight Distribution at SAE Carry (unloaded) – Rear	kg	21 759	21 573	21 373	21 212	21 579	20 829
	lb	47,970	47,560	47,119	46,765	47,574	45,920
Weight Distribution at SAE Carry (loaded) – Front	kg	39 169	39 653	40 168	40 571	39 642	41 621
	lb	86,353	87,421	88,554	89,445	87,395	91,759
Weight Distribution at SAE Carry (loaded) – Rear	kg	15 085	14 832	14 562	14 333	14 749	13 710
	lb	33,257	32,699	32,104	31,599	32,516	30,226

BOCE = Bolt-on Cutting Edge

986K Wheel Loader Specifications

Operating Specifications – Standard Lift Aggregate Package

Bucket Type		General Purpose				Coal
Ground Engaging Tools		BOCE				BOCE
Cutting Edge Type		Straight				Straight
Bucket Part No.		512-1180	513-7400	513-7420	477-1900	513-7450
Struck Capacity	m ³	5.2	5.9	6.6	7.3	9.0
	yd ³	6.8	7.7	8.6	9.6	11.8
Heaped Capacity (rated)	m ³	6.1	6.9	7.7	8.4	10.3
	yd ³	8.0	9.0	10.0	11.0	13.5
Width	mm	3729	3729	3729	3729	3729
	ft	12.2	12.2	12.2	12.2	12.2
Dump Clearance at Full Lift and 45° Discharge (edge)	mm	3488	3403	3311	3222	3117
	ft	11.4	11.2	10.9	10.6	10.2
Dump Clearance at Full Lift and 45° Discharge (with teeth)	mm	—	—	—	—	—
	ft	—	—	—	—	—
Reach at Lift and 45° Discharge (edge)	mm	1815	1900	1992	2081	2161
	ft	6.0	6.2	6.5	6.8	7.1
Reach at Lift and 45° Discharge (with teeth)	mm	—	—	—	—	—
	ft	—	—	—	—	—
Reach with Lift Arms Horizontal and Bucket Level	mm	3396	3516	3646	3772	3903
	ft	11.1	11.5	12.0	12.4	12.8
Digging Depth	mm	143	143	143	143	160
	in	5.6	5.6	5.6	5.6	6.3
Overall Length	mm	10 589	10 709	10 839	10 965	11 110
	ft	34.7	35.1	35.6	36.0	36.4
Overall Height with Bucket at Full Raise	mm	6860	6964	7078	7000	7219
	ft	22.5	22.8	23.2	23.0	23.7
Loader Clearance Turning Radius (SAE carry with teeth)	mm	8663	8693	8727	8761	8832
	ft	28.4	28.5	28.6	28.7	29.0
Full Dump Angle	deg	-50	-50	-50	-50	-50
Static Tipping Load Straight (no tire squash)	kg	35 054	34 650	34 230	33 873	33 451
	lb	77,281	76,389	75,464	74,676	73,746
Static Tipping Load Straight (with tire squash)	kg	33 028	32 605	32 162	31 785	31 281
	lb	72,814	71,882	70,905	70,074	68,963
Static Tipping Load – Full Turn (articulated 35°) (no tire squash)	kg	30 959	30 571	30 168	29 827	29 404
	lb	68,254	67,398	66,509	65,758	64,824
Static Tipping Load – Full Turn (articulated 35°) (with tire squash)	kg	27 835	27 421	26 989	26 625	26 099
	lb	61,366	60,453	59,500	58,698	57,538
Breakout Force	kN	374	346	319	297	275
	lbf	84,131	77,794	71,825	66,831	61,799
Operating Weight	kg	46 695	46 926	47 170	47 345	47 772
	lb	102,944	103,453	103,991	104,377	105,318
Weight Distribution at SAE Carry (unloaded) – Front	kg	20 746	21 163	21 607	21 942	22 752
	lb	45,736	46,655	47,635	48,374	50,160
Weight Distribution at SAE Carry (unloaded) – Rear	kg	25 949	25 763	25 563	25 402	25 019
	lb	57,208	56,798	56,356	56,003	55,158
Weight Distribution at SAE Carry (loaded) – Front	kg	41 929	42 431	42 965	43 387	44 501
	lb	92,438	93,545	94,720	95,652	98,109
Weight Distribution at SAE Carry (loaded) – Rear	kg	17 466	17 195	16 906	16 659	15 971
	lb	38,507	37,909	37,271	36,726	35,210

BOCE = Bolt-on Cutting Edge

986K Wheel Loader Specifications

Operating Specifications – High Lift

Bucket Type		Rock			HD Rock
Ground Engaging Tools		Teeth & Segments			Teeth & Segments
Cutting Edge Type		Spade			Spade
Bucket Part No.		527-4050	527-4060	525-6140	527-4070
Struck Capacity	m ³	4.4	4.8	5.1	4.4
	yd ³	5.8	6.2	6.7	5.8
Heaped Capacity (rated)	m ³	5.4	5.7	6.1	5.4
	yd ³	7.0	7.5	8.0	7.0
Width	mm	3812	3812	3812	3840
	ft	12.5	12.5	12.5	12.6
Dump Clearance at Full Lift and 45° Discharge (edge)	mm	3821	3775	3737	3805
	ft	12.5	12.4	12.3	12.5
Dump Clearance at Full Lift and 45° Discharge (with teeth)	mm	3623	3577	3538	3575
	ft	11.9	11.7	11.6	11.7
Reach at Lift and 45° Discharge (edge)	mm	1995	2041	2080	2042
	ft	6.5	6.7	6.8	6.7
Reach at Lift and 45° Discharge (with teeth)	mm	2163	2209	2248	2216
	ft	7.1	7.2	7.4	7.3
Reach with Lift Arms Horizontal and Bucket Level	mm	4184	4249	4304	4255
	ft	13.7	13.9	14.1	14.0
Digging Depth	mm	203	203	203	181
	in	8.0	8.0	8.0	7.1
Overall Length	mm	11 471	11 536	11 591	11 528
	ft	37.6	37.8	38.0	37.8
Overall Height with Bucket at Full Raise	mm	7174	7230	7276	7174
	ft	23.5	23.7	23.9	23.5
Loader Clearance Turning Radius (SAE carry with teeth)	mm	8914	8932	8948	8952
	ft	29.2	29.3	29.4	29.4
Full Dump Angle	deg	-50	-50	-50	-50
Static Tipping Load Straight (no tire squash)	kg	29 417	29 221	29 070	28 415
	lb	64,853	64,422	64,088	62,644
Static Tipping Load Straight (with tire squash)	kg	27 919	27 714	27 555	26 924
	lb	61,551	61,099	60,748	59,357
Static Tipping Load – Full Turn (articulated 35°) (no tire squash)	kg	25 805	25 616	25 471	24 803
	lb	56,891	56,473	56,153	54,682
Static Tipping Load – Full Turn (articulated 35°) (with tire squash)	kg	23 428	23 225	23 070	22 436
	lb	51,650	51,202	50,861	49,463
Breakout Force	kN	336	323	312	324
	lbf	75,501	72,547	70,222	72,875
Operating Weight	kg	47 425	47 552	47 638	48 325
	lb	104,553	104,833	105,023	106,537
Weight Distribution at SAE Carry (unloaded) – Front	kg	22 883	23 132	23 304	24 558
	lb	50,449	50,997	51,377	54,140
Weight Distribution at SAE Carry (unloaded) – Rear	kg	24 541	24 420	24 333	23 767
	lb	54,104	53,837	53,646	52,397
Weight Distribution at SAE Carry (loaded) – Front	kg	40 772	41 053	41 255	42 438
	lb	89,886	90,507	90,952	93,559
Weight Distribution at SAE Carry (loaded) – Rear	kg	16 653	16 498	16 382	15 887
	lb	36,713	36,372	36,117	35,024

986K Wheel Loader Specifications

Operating Specifications – High Lift

Bucket Type		General Purpose				Serrated	Coal
Ground Engaging Tools		BOCE					BOCE
Cutting Edge Type		Straight				Spade	Straight
Bucket Part No.		512-1180	513-7400	513-7420	477-1900	519-1465	513-7450
Struck Capacity	m ³	5.2	5.9	6.6	7.3	5.1	9.0
	yd ³	6.8	7.7	8.6	9.6	6.7	11.8
Heaped Capacity (rated)	m ³	6.1	6.9	7.7	8.4	6.1	10.3
	yd ³	8.0	9.0	10.0	11.0	8.0	13.5
Width	mm	3729	3729	3729	3729	3812	3729
	ft	12.2	12.2	12.2	12.2	12.5	12.2
Dump Clearance at Full Lift and 45° Discharge (edge)	mm	3946	3862	3770	3680	3787	3575
	ft	12.9	12.7	12.4	12.1	12.4	11.7
Dump Clearance at Full Lift and 45° Discharge (with teeth)	mm	—	—	—	—	3590	—
	ft	—	—	—	—	11.8	—
Reach at Lift and 45° Discharge (edge)	mm	1888	1972	2064	2154	2086	2234
	ft	6.2	6.5	6.8	7.1	6.8	7.3
Reach at Lift and 45° Discharge (with teeth)	mm	—	—	—	—	2283	—
	ft	—	—	—	—	7.5	—
Reach with Lift Arms Horizontal and Bucket Level	mm	3760	3880	4010	4136	4292	4267
	ft	12.3	12.7	13.2	13.6	14.1	14.0
Digging Depth	mm	190	190	190	190	163	208
	in	7.5	7.5	7.5	7.5	6.4	8.2
Overall Length	mm	11 039	11 159	11 289	11 415	11 552	11 558
	ft	36.2	36.6	37.0	37.5	37.9	37.9
Overall Height with Bucket at Full Raise	mm	7319	7423	7536	7459	7237	7677
	ft	24.0	24.4	24.7	24.5	23.7	25.2
Loader Clearance Turning Radius (SAE carry with teeth)	mm	8861	8894	8931	8967	8967	9038
	ft	29.1	29.2	29.3	29.4	29.4	29.7
Full Dump Angle	deg	-50	-50	-50	-50	-50	-50
Static Tipping Load Straight (no tire squash)	kg	29 955	29 587	29 204	28 884	29 533	28 457
	lb	66,040	65,229	64,385	63,679	65,109	62,736
Static Tipping Load Straight (with tire squash)	kg	28 416	28 027	27 623	27 283	28 019	26 790
	lb	62,646	61,789	60,898	60,149	61,771	59,062
Static Tipping Load – Full Turn (articulated 35°) (no tire squash)	kg	26 339	25 984	25 614	25 307	25 943	24 879
	lb	58,068	57,285	56,470	55,793	57,194	54,848
Static Tipping Load – Full Turn (articulated 35°) (with tire squash)	kg	23 905	23 528	23 134	22 807	23 544	22 295
	lb	52,701	51,870	51,002	50,281	51,906	49,152
Breakout Force	kN	374	346	319	297	323	275
	lbf	84,040	77,709	71,746	66,757	72,571	61,739
Operating Weight	kg	47 075	47 306	47 550	47 725	47 211	48 152
	lb	103,782	104,291	104,829	105,215	104,081	106,156
Weight Distribution at SAE Carry (unloaded) – Front	kg	22 131	22 576	23 049	23 406	22 457	24 251
	lb	48,790	49,771	50,815	51,601	49,509	53,463
Weight Distribution at SAE Carry (unloaded) – Rear	kg	24 944	24 730	24 500	24 319	24 754	23 901
	lb	54,992	54,520	54,014	53,613	54,572	52,693
Weight Distribution at SAE Carry (loaded) – Front	kg	40 035	40 546	41 088	41 512	40 498	42 557
	lb	88,262	89,389	90,584	91,518	89,282	93,821
Weight Distribution at SAE Carry (loaded) – Rear	kg	17 039	16 760	16 461	16 213	16 713	15 595
	lb	37,566	36,948	36,291	35,743	36,845	34,381

BOCE = Bolt-on Cutting Edge

986K Standard Equipment

Standard Equipment

Standard equipment may vary. Consult your Cat dealer for details.

ELECTRICAL

- Alarm, back-up
- Alternator, single 145 amp
- Batteries, dry
- Converter, 10/15 amp, 24V to 12V
- Lighting system (halogen, work lights, access and service platform lighting)
- Starting and charging system, 24V
- Starter emergency start receptacle

OPERATOR ENVIRONMENT

- Graphical Information Display, displays real time operating information, performs calibrations and customizes operator settings
- Air conditioner
- Rear vision camera system
- Cat Production Measurement ready
- Cab, sound suppressed and pressurized, integrated rollover protective structure (ROPS/FOPS) radio ready for entertainment, includes antenna, speakers and converter (12-volt 5-amp) and power port
- Controls, lift and tilt function
- Heater, defroster
- Horn, electric
- Instrumentation, gauges
 - Coolant temperature
 - Fuel level
 - DEF level
 - Hydraulic oil temperature
 - Power train oil temperature
- Light, cab, dome
- Lunchbox, beverage holders
- Mirrors, rearview (externally mounted)
- Seat, Cat Comfort (cloth), air suspension, six-way adjustable
- Seat belt minder
- Seat belt, retractable, 76 mm (3 in) wide
- STIC Control System
- UV glass
- Transmission gear indicator
- Wet-Arm wipers/washers (front and rear)
 - Intermittent front and rear wipers
- Lights, directional

POWER TRAIN

- Brakes, oil-cooled, multi-disc, service/secondary
- Case drain screens
- Crankcase guard
- Electro hydraulic parking brake
- Engine, C15 ACERT MEUI diesel, turbocharged/aftercooled
- Ground level engine shutoff
- Turbine precleaner, engine air intake
- Starting aid, ether, automatic
- Torque converter, Neutralizer
- Transmission, planetary powershift, 4F/3R electronic control
- Manual switch and automatic fuel priming

OTHER

- Automatic bucket lift kickout/positioner
- Hydraulically driven demand fan
- Couplings, Cat O-ring face seals
- Doors, service access (locking)
- Ecology drains for engine, radiator, hydraulic tank
- Fuel tank, 535 L (141 gal)
- Hitch, drawbar with pin
- Hoses, Cat XT™
- Hydraulic, steering and brake filtration/screening system
- Cat Clean Emission Module
- Oil sampling valves
- Premixed 50% concentration of extended life coolant with freeze protection to -34° C (-29° F)
- Rear access to cab and service platform
- Steering, load sensing
- Toe kicks
- Vandalism protection caplocks

Optional Equipment

With approximate changes in operating weights, optional equipment may vary. Consult your Cat dealer for specifics.

POWER TRAIN

- -50° C (-58° F) antifreeze
- Engine oil change system, high speed, Wiggins
- Engine block heater 120V or 240V
- High ambient cooling – software
- Cat Production Measurement

MISCELLANEOUS ATTACHMENTS

- Front and rear roading fenders
- Fast fill fuel system (Shaw-Aero)
- Cold Weather Starting (extra two batteries)
- Aggregate Handler
- Wheel chocks

OPERATOR ENVIRONMENT

- Cab powered precleaner
- Cat Detect Vision
- AM/FM/CD/MP3 radio
- Satellite Sirius radio with Bluetooth
- LED warning strobe
- CB radio ready
- Window pull down visor
- Handrail mounted mirrors

Mandatory Attachments

Select one from each group. Mandatory and optional equipment may vary. Consult your Cat dealer for specifics.

LINKAGE

- Standard with two valves
- Standard with three valves
- High Lift with two valves
- High Lift with three valves
- Autolube
- Manual grease pins

ELECTRICAL

- No Product Link
- Product Link (Satellite)
- Product Link (Cellular)
- Product Link (China Only)

STEERING

- Standard steering
- Secondary steering

POWER TRAIN

- Axle oil cooling
- No axle oil cooling
- Standard axles
- Standard fuel lines
- Heated fuel lines
- No engine brake
- Engine brake

LIGHTING

- Standard lighting
- LED lighting

OPERATOR ENVIRONMENT

- No suppression arrangement
- Sound suppression
- Standard seat
- Heated and ventilated seat
- Standard seat belt
- 4 point seat belt
- Standard cab glass
- Rubber mounted cab glass
- Standard mirror
- Rear vision display
- Rear vision display with Cat Detect (Object Detection)

HYDRAULICS

- Ride control
- No ride control
- Standard hydraulic oil
- Fire resistant (EcoSafe) hydraulic oil
- Cold weather hydraulic oil



For more complete information on Cat products, dealer services, and industry solutions, visit us on the web at www.cat.com

AEHQ7984-01 (05-2018)
Replaces AEHQ7984

© 2018 Caterpillar
All rights reserved

Materials and specifications are subject to change without notice. Featured machines in photos may include additional equipment. See your Cat dealer for available options.

CAT, CATERPILLAR, SAFETY.CAT.COM, their respective logos, "Caterpillar Yellow" and the "Power Edge" trade dress, as well as corporate and product identity used herein, are trademarks of Caterpillar and may not be used without permission.

VisionLink is a trademark of Trimble Navigation Limited, registered in the United States and in other countries.

